

# QUARTERMILKER 8-litre

## INSTRUCTIONS FOR USE

Before first use, a smear of lubricant on the O-ring can ease attachment of the lid to the bowl.

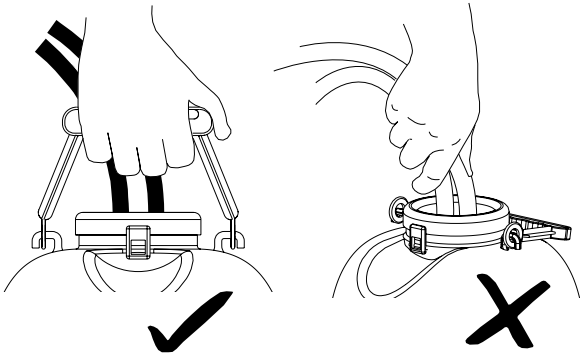

- 1** Carry your Quartermilker by the handle, NOT by the rubber tubes.

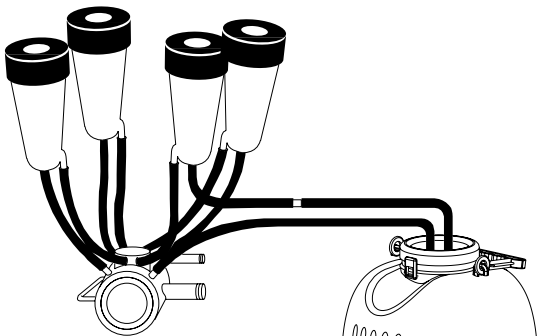

- 2** Connect the Quartermilker to the claw by disconnecting the required inflation and joining it the plastic connector on the Quartermilker tube. The other Quartermilker tube (the one attached to the lid at the safety valve) is then connected to the milking claw.

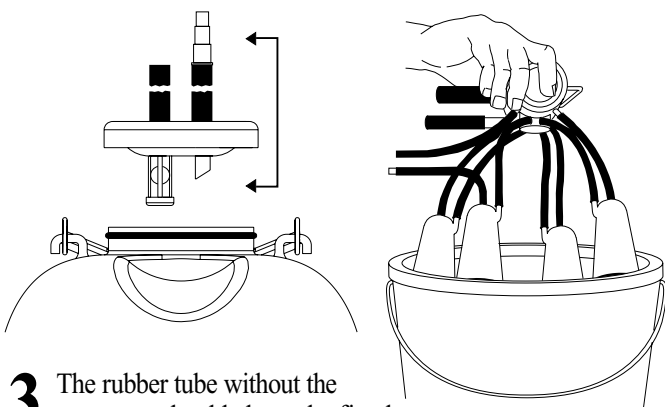

- 3** The rubber tube without the connector should always be fitted to the side of the lid with the safety valve. If the valve becomes close while attaching the cluster to the cow, squeezing this tube temporarily can cause the valve to open again.

- 4** The whole milking cluster should be immersed and soaked in an antiseptic solution after removal from an infected cow.

## CLEANING

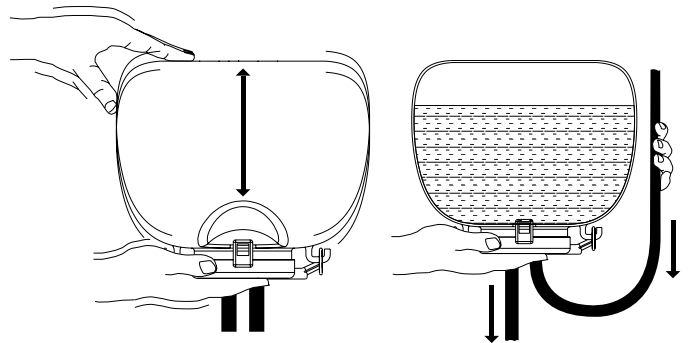

Fill the bowl of the Quartermilker with warm water and detergent. Attach the lid assembly and agitate thoroughly while holding upside down. Lift the rubber tubes alternately to syphon air and wash liquid through.

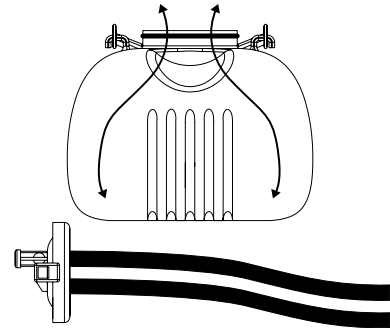

After cleaning, drain all sanitizing solutions from the bowl and lid assembly, and **leave open to air dry**. Do not disconnect the rubber hoses from the lid more often than necessary. Occasionally soak the whole assembly in acid solution and use a brush to thoroughly remove any milk and mineral deposits from the bowl, lid and all tubes.

## PARTS LIST

